

Dual Adjustable Hinge

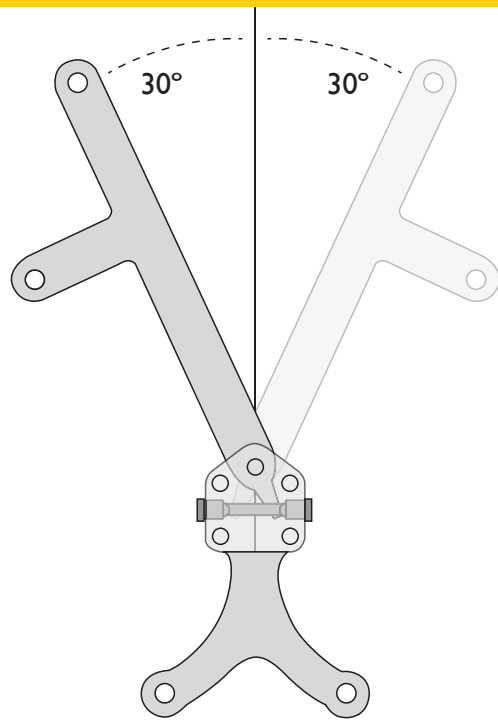

- All stainless steel construction for stronger, longer-lasting control
- Lightweight, total weight only 1.5 oz/hinge
- Taller, reversible stainless steel upright helps to corrugate plastic strut, reducing the need for thicker plastics
- Allows for AFOs to be fabricated with plastic as thin as 3/32"
- Adjustable stops allow movement from 0° to 30° in both direction
- Ultra-small joint head to reduce overall bulk
- Super low-profile at just over 1/4" thick (lower profile than most polyurethane hinges)
- Contourable, distal stirrup attachment increases strength of connection to molded footplate

Hinge Adjustment Instructions

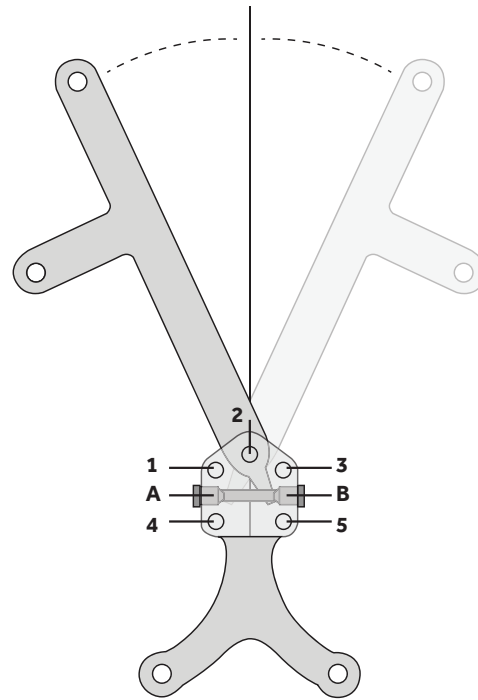

1. Determine proper position or ROM for hinge
 2. Loosen two faceplate screws (1, 3)
 3. Adjust set screws (A, B) as to provide desired position or ROM
 4. Tighten two faceplate screws (1, 3) to lock adjustable set screws (A, B)
 5. Take care to avoid over tightening of center axis screw (2) during assembly
- Apply (medium strength) thread lock compound (included) to all screws (1-5) during final assembly



TECHNICAL SUPPORT 877.462.0711

17530 Dugdale Dr. | South Bend, IN 46635 | www.surestep.net



Dual Adjustable Hinge



Fabrication and Adjustment
Instructions

Prior to filling impression, determine what method will be used to contour hinges:

Method 1 **4-40 Threaded rod through positive model**

Method 2 **Contouring / Alignment fixture**

Method 1: Using a Threaded Rod

Mold Preparation

- Locate medial and lateral joint axis and position a 4-40 threaded rod, accordingly, prior to filling cast.
- Modify positive model as desired. Minimum of 3/16" build up on both medial and lateral malleoli is recommended

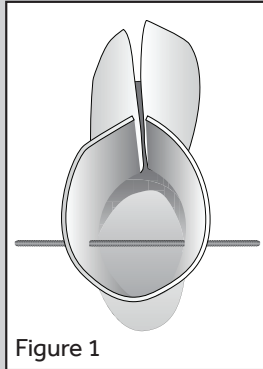

Figure 1

Hinge Preparation

- Thread a 4-40 nut onto both medial and lateral sides and tighten against positive model. Nuts should act as spacers to keep hinges approximately 1/8" off positive model
- Remove center axis screw from hinges. Most proximal assembly screw on faceplate
- Slide hinge (at center axis point) over threaded rod

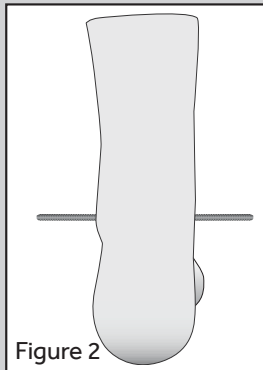

Figure 2

Continue with instructions on next page

Method 2: Using Contouring/Alignment Fixture

Mold Preparation

- Modify positive model as desired. Minimum of 3/16" build up on both medial and lateral malleoli is recommended

Hinge Preparation

- Attach medial and lateral hinges to fixture and align both with the desired joint axis.

Continue with instructions on next page

Instructions Continued (Use for both methods)

1. Contour proximal uprights and "AP Stabilizer Tab" to positive model. See Figure 3

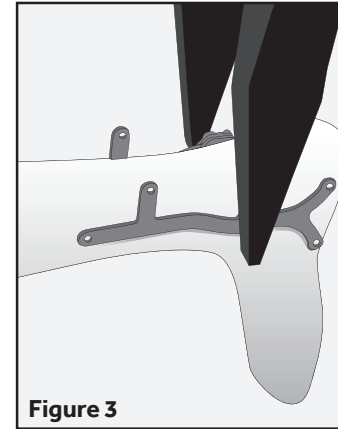

Figure 3

2. Contour distal "Y" stirrups to positive model. See Figure 4

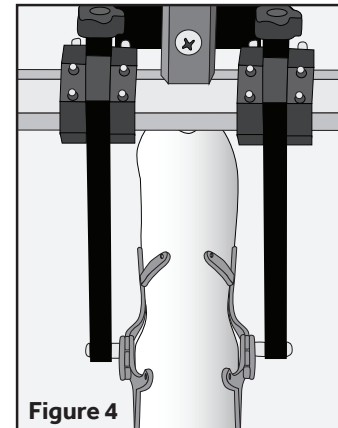

Figure 4

3. Remove hinges and attach 1/8" cork spacers (provided) to ensure proper spacing between hinge and positive model. See Figure 5

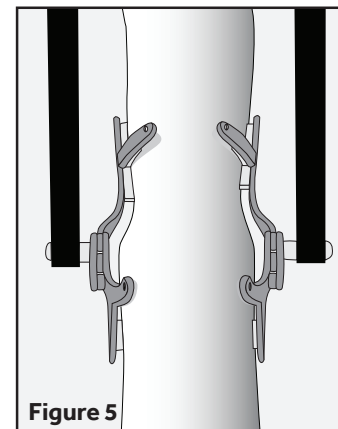

Figure 5

4. Affix hinges to positive model using nails or small wood screws. See Figure 6

5. Fill any gaps between positive model and hinges with modeling clay or similar material.

6. Vacuum form using standard procedures.

7. After cooling separate proximal and distal sections and remove AFO as normal.

It is recommended that a hot knife be used over joint head, upright or stirrup during removal.

DO NOT USE CAST CUTTER OR SAW OVER STAINLESS STEEL JOINT HEAD, AS IT MAY DAMAGE THE HINGE.

8. Finish all plastic edges as normal.

9. Mark additional holes for assembly on "Y" stirrup attachment and proximal upright. See Figure 7

Holes should be marked and drilled to 1/8" diameter and located as close to joint head as plastic trimlines will allow.

These additional attachment holes help to create necessary additional strength and are critical.

DO NOT SKIP THIS STEP.

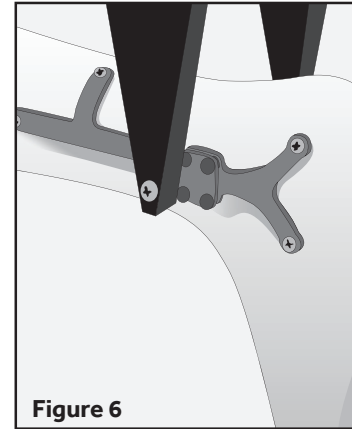

Figure 6

10. Mark and drill remaining assembly holes in plastic, for attachment of hinges.

11. Assemble AFO by installing hinges.

Hinges can be attached to plastic AFO using Chicago type screws or copper rivets.

If using Chicago type screws, drill all assembly holes in stirrups and uprights to 7/32" to allow posts to pass through.

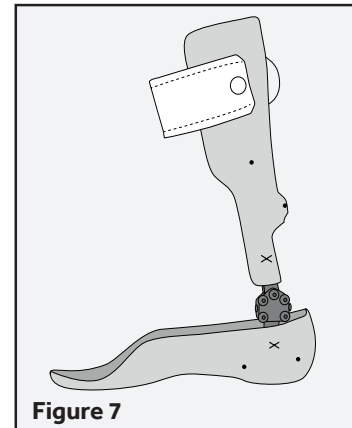

Figure 7

12. Use thread locking compound (included) on all screws to avoid loosening.

Hinges can be attached to plastic AFO using speedy rivets with proper rivet tooling.

DO NOT ASSEMBLE USING SPEEDY RIVETS WITH HAMMER AND/OR RIVET BAR.

13. It is recommended that proximal strut be lined with moderately firm EVA foam to smooth the interior surface.